

Modular Cooking Range Line EVO700 Two Wells Freestanding Electric Fryer 14 liter

ITEM # _____

MODEL # _____

NAME # _____

SIS # _____

AIA # _____

**372085 (Z7FREH2FF0)**

14+14-lt electric fryer with 2 wells and 2 baskets (internal heating elements) - free standing

372144 (Z7FREH2FFN)

14+14-lt electric fryer with 2 wells and 2 baskets (internal heating elements) - free standing

Short Form Specification

Item No. _____

To be installed on height adjustable feet in stainless steel. High efficiency tilting incoloy armoured heating elements (17.4kW) placed inside the wells. Deep drawn wells. Oil drains through a tap into a container under the well. Exterior panels in stainless steel with Scotch Brite finish. One piece pressed work top in 1.5 mm thick stainless steel. Right-angled side edges to allow flush-fitting junction between units.

Main Features

- Unit to be mounted on height adjustable feet in stainless steel.
- Thermostatic regulation of oil temperature up to a maximum of 185 °C.
- Overheat protection thermostat as standard on all units.
- Oil drains through a tap into a drainage container positioned under the well.
- All major compartments located in front of unit for ease of maintenance.
- IPX 4 water protection.
- Incoloy armoured heating elements located inside the well can be lifted up for easier cleaning.
- Optional portable oil quality monitoring tool (code 9B8081) for efficient oil management.

Construction

- Interior of well with rounded corners for ease of cleaning.
- All exterior panels in Stainless Steel with Scotch Brite finishing.
- One piece pressed 1.5 mm work top in Stainless steel.
- Model has right-angled side edges to allow flush fitting joints between units, eliminating gaps and possible dirt traps.

APPROVAL: _____

Included Accessories

- 2 of Door for open base cupboard PNC 206342
- 2 of Basket for 14 and 15lt fryers PNC 921691

Optional Accessories

- Junction sealing kit PNC 206086
- 4 wheels, 2 swivelling with brake (EVO700/900). It is mandatory to install with base supports for feet/wheels. PNC 206135
- Flanged feet kit PNC 206136
- Frontal kicking strip for concrete installation, 800 mm PNC 206148
- Frontal kicking strip for concrete installation, 1000 mm PNC 206150
- Frontal kicking strip for concrete installation, 1200 mm PNC 206151
- Frontal kicking strip for concrete installation, 1600 mm PNC 206152
- Frontal handrail 800 mm PNC 206167
- Frontal kicking strip, 800 mm PNC 206176
- Frontal kicking strip, 1000 mm PNC 206177
- Frontal kicking strip, 1200 mm PNC 206178
- Frontal kicking strip, 1600 mm PNC 206179
- Large handrail (portioning shelf) 800 mm PNC 206186
- Frontal handrail 1200 mm PNC 206191
- Frontal handrail 1600 mm PNC 206192
- 4 feet for concrete installation (not for 900 line freestanding grill) PNC 206210
- Right and left side handrails PNC 206240
- Pair of side kicking strips PNC 206249
- Pair of side kicking strips (concrete installation) PNC 206265
- Chimney upstand, 800 mm PNC 206304
- 2 side covering panels, height 700 mm, depth 700 mm PNC 206319
- Door for open base cupboard PNC 206342
- Base support for feet or wheels - 800mm (EVO700/900) PNC 206367
- Base support for feet or wheels - 1200mm (EVO700/EVO900) PNC 206368
- Base support for feet or wheels - 1600mm (EVO700/900) PNC 206369

- Rear paneling - 800mm (EVO700/900) PNC 206374
- Rear paneling - 1000mm (EVO700/900) PNC 206375
- Rear paneling - 1200mm (EVO700/900) PNC 206376
- Chimney grid net, 400mm PNC 206400
- Basket for 14 and 15lt fryers PNC 921691
- 2 half size baskets for 12, 14 and 15lt fryers PNC 921692
- Filter for fryer oil collection basin for 7lt, 14lt, 15lt free standing fryers PNC 921693

Modular Cooking Range Line EVO700 Two Wells Freestanding Electric Fryer 14 liter

Front

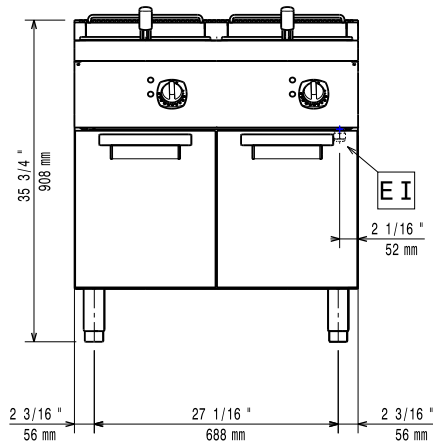

Side

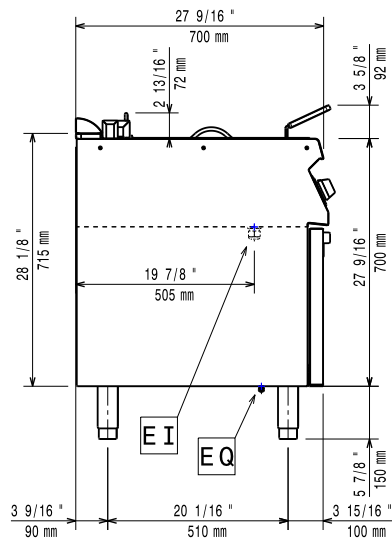

EI = Electrical inlet (power)
EQ = Equipotential screw

Top

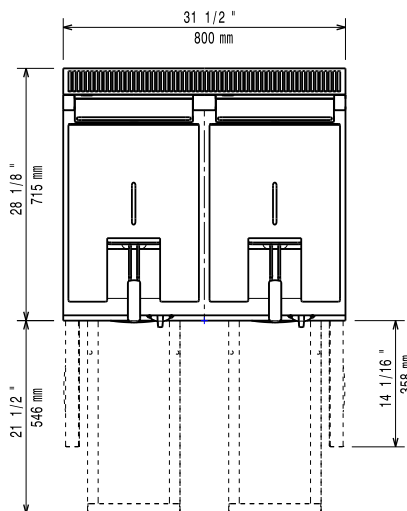

Electric

Supply voltage:

372085 (Z7FREH2FF0) 380-400 V/3N ph/50/60 Hz
372144 (Z7FREH2FFN) 230 V/3 ph/50/60 Hz

Total Watts:

17.4 kW

Predisposed for:

372085 (Z7FREH2FF0) 380-400V 3N~ 50/60Hz
15,7-17,4kW

Key Information:

Usable well dimensions (width): 240 mm
Usable well dimensions (height): 285 mm
Usable well dimensions (depth): 380 mm
Well capacity: 12 lt MIN; 14 lt MAX
Thermostat Range: 105 °C MIN; 185 °C MAX
Net weight: 81 kg
Shipping weight:
372085 (Z7FREH2FF0) 82 kg
372144 (Z7FREH2FFN) 101 kg
Shipping height:
372085 (Z7FREH2FF0) 1130 mm
372144 (Z7FREH2FFN) 1140 mm
Shipping width: 820 mm
Shipping depth: 860 mm
Shipping volume: 0.8 m³

If appliance is set up or next to or against temperature sensitive furniture or similar, a safety gap of approximately 150 mm should be maintained or some form of heat insulation fitted.

Certification group:

372085 (Z7FREH2FF0) EF17214
372144 (Z7FREH2FFN) N7FE2